

# ANALYZER AIR

Dual energy X-ray  
Absorptiometry  
Bone Densitometry

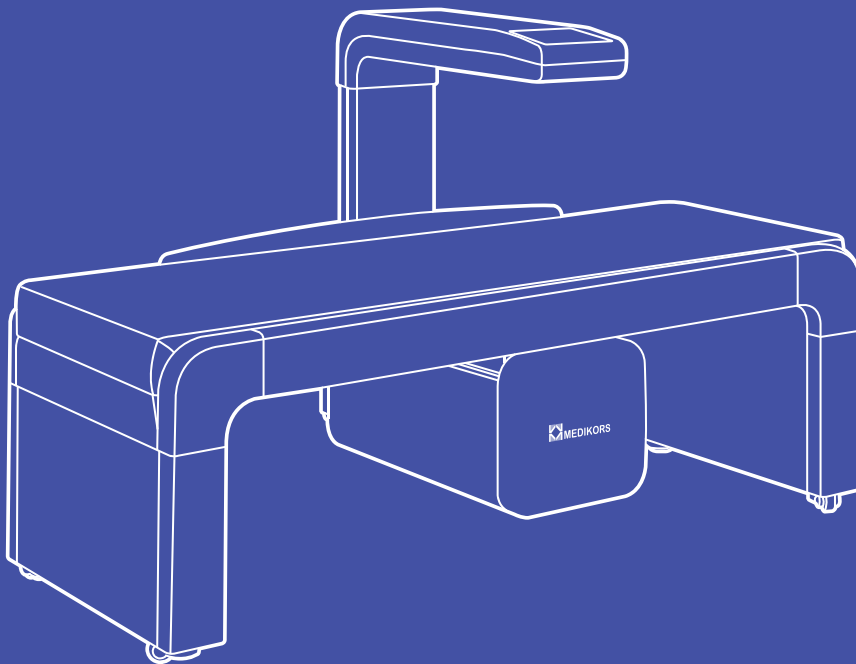

## At MEDIKORS Inc.

over 30% of the staff are researchers. As a technology-oriented company, we have been conducting various national R&D projects. In 2014, we launched the world's first 108- $\mu\text{m}$  body composition analyzer for experimental animals, which is being supplied to universities, university hospitals, and national and public research centers. Based on our technological competence, MEDIKORS secured a high level of precision and radical price competitiveness, with which we entered the human medical equipment market and have been constantly striving to contribute to distributing useful medical diagnosis and analysis technologies.

MEDIKORS values infinite challenge, sense of responsibility, craftsmanship, and humanity, and strives to discover technologies and provide products and services that enrich human life and happiness, with creative and honest staff. Under the slogan, 'Imagine the image', we believe constant development of technology enriches human life, and try to provide a variety of high-tech products and services that are user-friendly.





**Osteoporosis refers to a medical condition in which the volume and strength of bones decrease due to qualitative changes that result in a higher risk of fracture.**

Known causes of osteoporosis include genetics, menopause, drugs including steroid, accompanying diseases, smoking, alcohol, and rheumatism, and the deteriorated bone density as a result of aging can lead to lift-threatening fracture of the spine or femoral region. Therefore, special and constant care is required. In most cases, osteoporosis does not present symptoms before bones become highly susceptible to fracture caused by external shock. Therefore, it is important to diagnose the disease and treat it base on exercise, diet, medication, etc. As a result of aging population, which was supported by the development of medical science, osteoporosis diagnosis by bone densitometry and the treatment became an essential field of the medicine.

Osteoporosis is diagnosed based on bone densitometry, using a T-score, which is based on the mean and standard deviation of the younger population of the same race and gender. When the score is -2.5 or lower, the patient is diagnosed with osteoporosis. Additionally, Z-score, which is based on the mean and standard deviation according to the age and gender of the patient, is taken into account for diagnosis.

**Methods of bone densitometry include dual energy x-ray absorptiometry (DXA), quantitative ultrasound (QUS), and quantitative computer tomography (QCT), with DXA being most commonly used.**

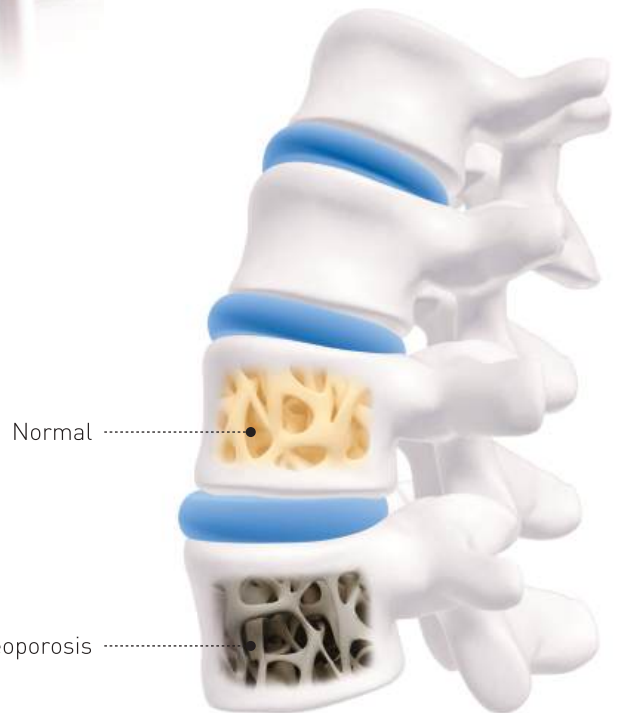

QUS measures the extremities of the body, with the advantage of lack of radiation exposure and, therefore, safety. However, it cannot directly measure the areas of high risk of fracture and, therefore, generally used for screening. DXA, on the other hand, causes radiation exposure, but directly measures the spine and hips, which are closely related to life maintenance. Also, it involves less artifacts in case of QCT and, therefore, ensures the most accurate results.

In addition to pain caused by fracture, osteoporosis can lead to reduced height, due to fracture of spine and reduced lung capacity, due to fracture of thoracic vertebra. Hip joint fracture requires hospitalization and surgery and long-term hospitalization increases risks of deep vein thrombosis and pulmonary thromboembolism, which can be fatal to the elderly who are susceptible to osteoporosis.



# 64 channel DXA Bone Densitometry

---

InAlyzer AIR uses 64ch dual-energy x-ray detector based on fan beam technology and obtains 64 rows of data per one X-ray irradiation, enabling acquisition of data of higher resolution in a shorter time, unlike pencil beam system that obtains 1 row of data per one X ray irradiation. Also, the reliability and durability was enhanced by using an x-ray generator that does not require fast switching between high energy and low energy, and the x-ray detector that acquires high-resolution data of high energy and low energy independently provides high-quality images.



**InAlyzerAIR has an open-bottom design and this results in not only a beautiful design but also, by locating the moving axis to the center of the moving part, minimizing the shaking between the x-ray generation and x-ray detection section during the scan and, thereby, maintaining accuracy in the measurement result.**

## Feature



### High resolution & Fast measurement

By applying the energy-fixed x-ray generator, we minimized the failure rate, while the energy-independent high-resolution detector provides fast high-resolution results.



### Wide inside & Compact outside

Our own equipment technology maximized the scan area, minimizing the patient's movement and external size for space efficiency in hospitals.



### Powerful & user-friendly Interface

In addition to high-resolution images, it provides various image-processing tools and the user-friendly ROI (Region Of Interest) enables convenient and accurate use of the analysis. Also, the self-diagnosis allows the equipment to maintain its performance and produce precise results.

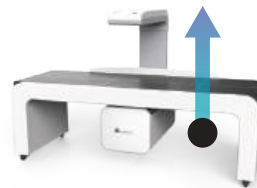

### Excellent & Robust design

As a product of a national R&D project, the equipment features a beautiful design, including the world-first open bottom of its kind, reduced rate of errors caused by vibration during scanning, and, therefore, high levels of accuracy and precision.



## Proven reliability

Our own DXA technology has been recognized and trusted by university hospitals and national research centers to which InAlyzer (laboratory equipment) is supplied.

# Software

Basic measurement is completed based on three pages – patient registry, measurement, analysis – and the maintenance page allows the machine to check its own performance daily or on a regular basis set by the user. The equipment provides optimal user convenience with intuitive operation.



[ Main Page ]



[ Result Page ]



[ Maintenance Page ]

## Specification

	ITEM	ITEM DETAIL	VALUE	
Performance		Precision	< 1.5% CV [Static condition]	
		Number of channels	64	
		Image Resolution	0.45mm (On bed surface)	
		Scan Area	490mm x 900mm	
	Scan Time		AP Spine	30 Sec.
			Right/ Left Femur	30 Sec.
			Right/ Left Forearm (Option)	30 Sec.
	Measurement Parameter	BMD, BMC, Area, T-score, Z-score		

In principle, bone densitometric images are not allowed to be used for diagnosis. However, the high resolution images are highly helpful for specialists when identifying skeletal structure. Also, DXA has become a common measurement of human body composition.



[ Spine BMD Image ]



[ Spine Raw Image ]

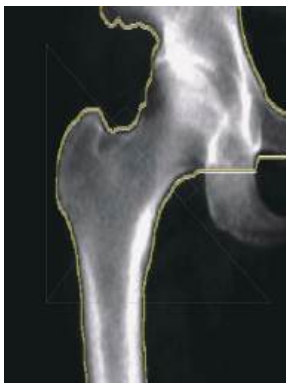

[ Femur BMD Image ]



[ Femur Raw Image ]

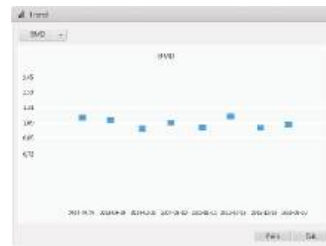

The trend analysis offers to monitor the comprehensive changes of patients Bone Mineral Density (BMD).

The treatment and clinical interventions require time to monitor.

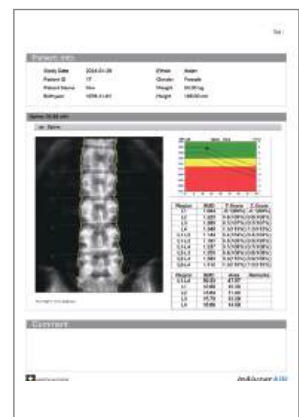
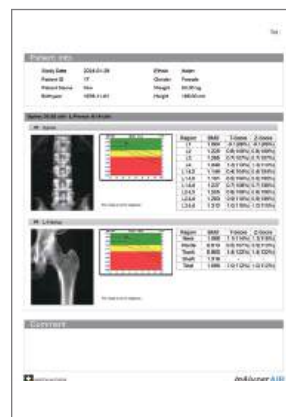

[ Result Report ]

InAnalyzer AIR provides precise BMD measurements with a comprehensive report to help monitor progress.

ITEM	ITEM DETAIL	VALUE
X-ray	Tube Voltage	99 kV
	Tube Current	3mA (max)
	Detector	Multilayer PD based, 128 Channel (64 High/ 64 Low)
Environment	Input Voltage and Frequency	110V, 220-230V 50/60 Hz
	Power Consumption	800VA
	Interface to PC system	Ethernet
	Dimension	1850(W) x 800(D) x 1162(H) mm
	Weight	138 kg

## For more information

For more information about products, visit  
[www.medikors.com](http://www.medikors.com)



**MEDIKORS Inc.**

Copyright©2016. MEDIKORS. All Right Reserved.

#F410, Seongnam Center M, 33 Sagimakgol-ro 62 beon-gil, Jungwon, Seongnam, Gyeonggi, Korea [13211]

Tel: +82-31-698-4905 Fax: +82-31-698-2007 Email: [sales@medikors.com](mailto:sales@medikors.com)